

Specifications

MODEL		GTH-3007	
MEASUREMENTS	Metric	Imperial	
Lifting height (max)	6.85 m	22 ft 6 in	
Lifting capacity (max)	3,000 kg	6,613 lbs	
Lift capacity at maximum height	2,500 kg	5,511 lbs	
Lift capacity at maximum reach	1,250 kg	2,755.5 lbs	
Forward reach (max)	3.8 m	12 ft 6 in	
Reach at maximum height	70 cm	2 ft 4 in	
A Height	2.05 m	6 ft 9 in	
B Height at steering wheel	1.33 m	4 ft 4 in	
C Width	2.0 m	6 ft 7 in	
D Inside cab width	86 cm	2 ft 10 in	
E Track	1.6 m	5 ft 3 in	
F Wheelbase	2.65 m	8 ft 7 in	
G Length at front wheels	4.09 m	13 ft 5 in	
H Length at fork-holder plate	4.69 m	15 ft 5 in	
I Ground clearance	41 cm	1 ft 4 in	
m1 Obstruction angle	90°	90°	
m2 Departure angle	52°	52°	

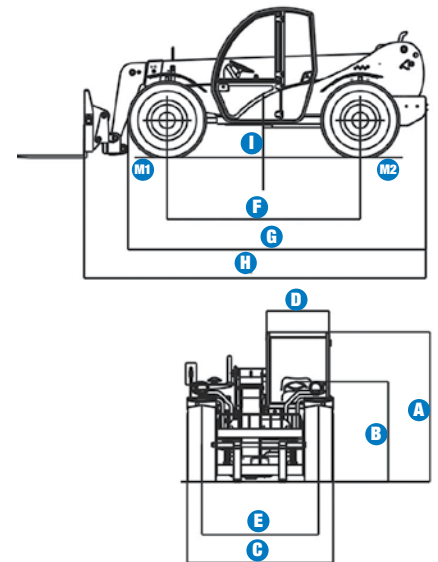

PRODUCTIVITY		
Inside/outside turning radius	2.2 m/4.05 m	7 ft 3 in/ 13 ft 3 in
Break out force (with 500L shovel SAE J 732/80)	3,762 kg	8,293 lbs
Towing capacity at dynamometer	6,500 kg	14,329 lbs
Travel speed (max)*	35 km/h	21.7 mph
Fork-holder plate rotation	135°	135°
Floating forks	Length 1200 mm Section 120x45mm	Length 47 in Section 5 in x 2 in
Tyres (DIN 70361)	405/70-20" PR14 8 holes wheel disc	

POWER		
Engine	Deutz Turbo Diesel 60 kW (81.5 hp), direct injection, low emission	
Tank capacities		
Fuel	92 L	20 gal
Engine oil	8 L	1.75 gal
Hydraulic oil	90 L	19.8 gal
Hydraulic output/pressure	80 L/min-280 bars	17.5 gal/min-4,061 psi

WEIGHT		
Weight**	6,000 kg	13226 lbs

STANDARDS COMPLIANCE Operating cab conforms to ISO3471 (ROPS) and ISO3449 (FOPS)
 Low emission engine conforms to UE 97/68 directives.

* With 24" tyres
 ** Weight will vary depending on options and/or country standards

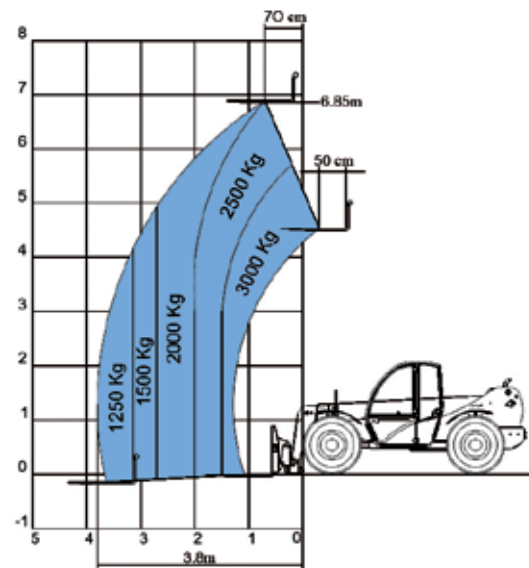

Lift capacity chart

EN 1459, Annex B

Features

STANDARD FEATURES

MEASUREMENTS

- 3000 kg (6,613.2 lbs) maximum lift capacity
- 6.85 m (22 ft 6 in) maximum lift height
- 3.8 m (12 ft 6 in) maximum forward reach

PRODUCTIVITY

- Four-wheel drive
- 3 steering modes:
 - front wheel steer
 - crab steer
 - coordinated steer
- Power assisted steering
- Front hydraulic stabilisers
- Quick coupling of tools from cab
- Two-speed hydrostatic motor coupled to a two-speed mechanical gearbox
- Multifunction proportional joystick hydraulically piloted
- Limited slip differential on front axle
- Floating forks
- Attachment holder plate with hydraulic coupling
- Adjustable suspended seat
- Large diameter steering wheel
- Front windscreen wipers
- Front & rear lights
- Oil immersed multi-disc brakes on front axle
- Lockable fuel tank
- Longitudinal stability control system with load monitor
- Visible display with coloured LEDs
- Audible alarm
- Automatic lock-out of boom extension and lowering
- Control enable switch

POWER

- Deutz Turbo Diesel 60 kW (81,5 hp)

OPTIONS & ACCESSORIES

PRODUCTIVITY

- Air conditioning
- Windshield protection grid
- Pre-arrangement for mixing bucket
- Additional armrest
- Adjustable spotlight
- Second hydraulic line in boom
- Pre-arrangement for hydraulic line on boom
- Special air filter

ATTACHMENT OPTIONS

- Forks side-shift (+/- 100 mm)
- 500 Lt concrete bucket, manual discharge
- 500 Lt concrete bucket, hydraulic discharge
- 2 m jib, 400 kg capacity
- 4 m jib, 900 kg capacity
- 4 m jib with 900 kg capacity hydraulic winch
- 800 Lt loading shovel
- 1200 Lt light material loading shovel
- Brick holder basket
- Fixed hook on plate
- 250 Lt concrete mixing bucket with remote control

TYRES

- Spare wheel 405/70-20" PR14

European Offices

UK

The Maltings
Wharf Road
Grantham NG31 6BH
UK
Tel: +44 (0)1476 584333
Fax: +44 (0)1476 584334

France

10, ZA de la Croix St. Mathieu
28320 Gallardon
France
Tel: +33 (0)2 37 26 09 99
Fax: +33 (0)2 37 26 09 98

Germany

Finienweg 3
28832 Achim/Bremen
Germany
Tel: +49 (0)4202 8852-0
Fax: +49 (0)4202 8852-25

Spain

Gaià 31, Pol. Ind. Pla d'en Coll
08110 Montcada i Reixac
Barcelona
Spain
Tel: +34 93 572 50 90
Fax: +34 93 572 50 91

Scandinavia

Tagenevägen 72
425 37 Hisings Kärra
Sweden
Tel: +46 31 57 51 00
Fax: +46 31 57 90 20

Genie United States

18340 NE 76th Street
P.O. Box 97030
Redmond, Washington 98073-9730
USA
Tel: +1 425 881-1800
Fax: +1 425 883-3475

WEB: www.genieindustries.com
Email: infoeurope@genieind.com

Distributed By:



WINCHESTER

01962 851155

SALISBURY

01722 341155

SOUTHAMPTON

02380 667666

Suppliers of Plant & Access Hire Equipment