

**Compaction Rollers (Walk Behind)**

<b>OPERATING WEIGHT</b>	476 - 700 kg
<b>GROSS ENGINE POWER</b>	5.4/5.5/6.0 kW (7.2/7.4/8.0 hp)
<b>DRUM WIDTH</b>	650 to 710mm
<b>STATIC LINEAR LOAD</b>	5.3 to 7.2 kg/cm
<b>CENTRIFUGAL FORCE</b>	9.0 to 16.0 kN



**COMPACTION ROLLERS**

- Single Drum (1-71 and MBR71) or Twin Drum (2-65)
- Drum widths from 650mm to 710mm - Operating weights from 476 to 700 kg.
- Powerful and reliable air cooled engines, with hydrostatic transmission for power.
- Superb service access and easy to service components.
- High quality heavy duty design with in-built vandal protection - “rental tough”.
- Heavy duty vibration system with high centrifugal force, frequency and static linear load reduces the number of passes required.
- Ergonomic control lever for simple and easy operation of all functions.

**Specifications (Performance)**

	1-71	MBR71	2-65
Total Static Basic Weight (kg)	461	500	680
Operating Weight (kg) CECE	476	512	700
Static Linear load (kg/cm)	6.7	7.2	5.3
Frequency - Hz (VPM)	65 (3900)	65 (3900)	62 (3720)
Amplitude (mm)	0.66	0.66	0.55
Centrifugal Force (kN)	9.0	9.0	16.0

### Dimensions

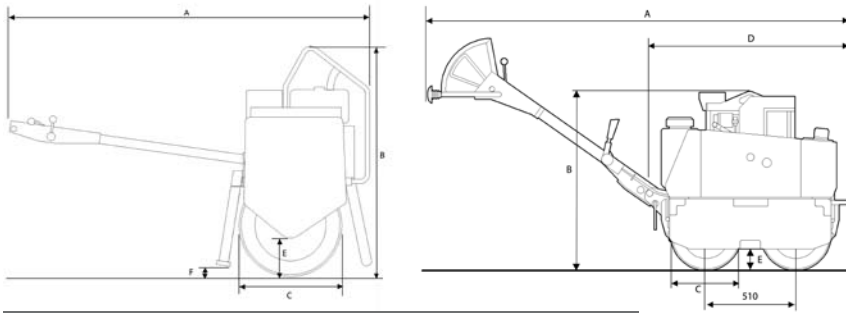

### Dimensions (mm)

	1-71	MBR71	2-65
A - Overall Length (mm)	2180	2180	2380
B - Overall Height (mm)	1300	1300	1030
C - Drum Diameter (mm)	575	575	400
D - Folded Length (mm)	n/a	n/a	1120
E - Curb Clearance (mm)	230	230	130
F - Ground Clearance (mm)	170	170	n/a
Overhang - Left / Right (mm)	20/110	20/110	100/25
Drum Width (mm)	710	710	650
Drum Shell Thickness (mm)	8.0	8.0	8.0

### Engine & Drive

	1-71	MBR71	2-65
Engine Make	Hatz		
Engine Model	1D41S		
Cylinders	1	1	1
Displacement (cc)	413	413	413
Cooling	Air		
Power - kW (HP)	5.4 (7.2)	5.5 (7.4)	6.0 (8.0)
Operating Speed (rpm)	2600		
Fuel Type	Diesel		
Drive	Hydrostatic		
Travel Speed (kph)	3.2	3.2	3.2
Braking System - Service	Dynamic Hydrostatic		
Braking System - Parking	Spring Apply / Hydraulic Release		



### Capacities

	1-71	MBR71	2-65
Hydraulic Tank Capacity (litres)	n/a	7.5	16
Fuel Tank Capacity (litres)	5	5	5
Water Tank Capacity (litres)	25	20	35

### Standard Equipment & Options

#### Standard Equipment

Gravity Fed Water System
Drum Scraper Bars Front and Rear (both drums on 2-65)
Removable plastic water and oil tanks for easy servicing (2-65 only)
Low maintenance battery
Emergency Release Free Wheel Valve (for Towing)* *(1-71 and MBR71 only)
Integral lifting points
Vandal Protection Package - Lockable instrument cover to deter vandals / thieves

#### Optional Equipment

Hydraulic Breaker attachment, tool, valve and hosing - 30 l/min (MBR71)
Tow behind trailer with breaker storage box (1-71 and MBR71)
Electric starting with Hour Meter